

CS371N: Natural Language Processing

Lecture 21: Dataset Bias and Spurious Correlations

Greg Durrett



Announcements

- ▶ Final project released (more details at the end of today's lecture)
- ▶ A5 due Tuesday



Recap

- ▶ Two methods for alignment:
 - ▶ Instruction tuning: supervised learning of LMs on data that looks like what we want them to do (answering questions, etc.)
 - ▶ RLHF: reinforcement learning with a learning reward model to encode preferences over trajectories
- ▶ This lecture: we're going to see what can go wrong with these kinds of fine-tuning approaches (on smaller LMs)



Recap

- ▶ **Pretraining (BERT):**
 - ▶ Train a big model to fill in masked-out words, then adapt it to other tasks. Led to big gains in **question answering** and **NLI** performance. BART/T5, GPT-3, etc. push this further.
- ▶ **Question answering (QA):**
 - ▶ "What was Marie Curie the first female recipient of?"
-> "The Nobel Prize" (find this span in a document containing the answer)
- ▶ **Natural language inference (NLI):**
 - ▶ "But I thought you'd sworn off coffee."
contradicts "I thought that you vowed to drink more coffee."



This Lecture

- Generalization in NLP
- Annotation artifacts and reasoning shortcuts for QA
- Annotation artifacts and reasoning shortcuts for NLI
- Solutions

Generalization



Model Performance

- If models can be fine-tuned on large datasets and perform very well on a held-out test dataset, is the problem solved?
- Examples: parsing, QA (ask questions about a Wikipedia article), ...
- What can go wrong?



Generalization

- If a model does well on train but poorly on test data, it *doesn't generalize*
- A model can do well on its test data and still fail to generalize *out of distribution* — arguably an even more important notion
- Many notions of generalization. Example: POS tagging

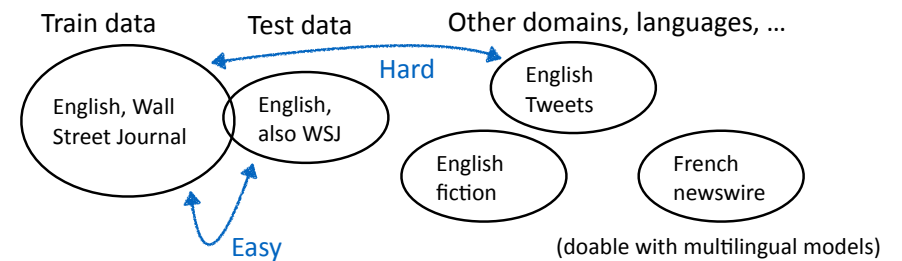



Generalization: QA

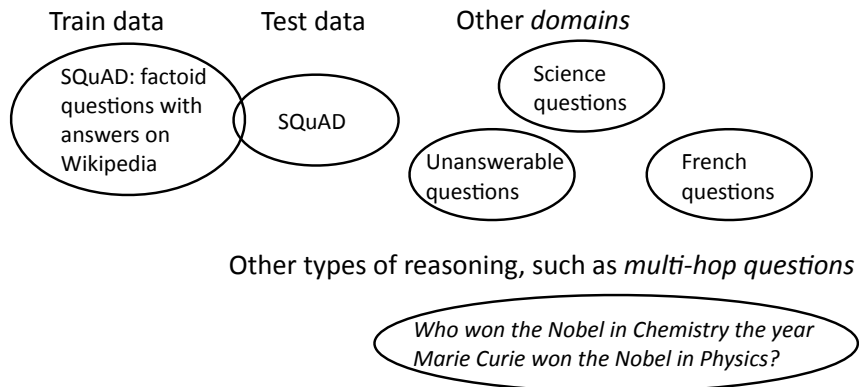

Generalization

- Just doing well on a single test set **is not that useful**
- We want POS taggers, QA systems, and more that can generalize to new settings so we can deploy them in practice. (ChatGPT is exciting partially because it generalizes really well to new tasks)
- Sometimes, you can get **very good test performance** but the model **generalizes very poorly**. How does this happen?

Annotation Artifacts, Reasoning Shortcuts: QA



Annotation Artifacts

- Some datasets might be easy because of how they're constructed, especially in QA and NLI

What becomes of Macbeth?

What does Macduff do to Macbeth?

What violent act does Macduff perform upon Macbeth?

- All questions have the same answer. But some are more easily guessable



Reminder: QA with BERT

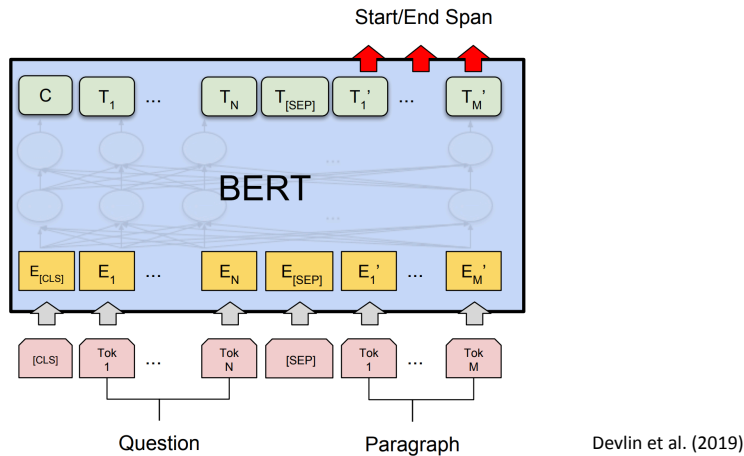

QA: Answer Type Heuristics

What degree did Martin Luther receive on October 19, 1512?

On October 19, 1512, Luther was awarded his doctorate of theology and, on October 21, 1512, was received into the senate of the theological faculty of the University of Wittenberg. He spent the rest of his career in this position at the University of Wittenberg.

- ▶ What should the model be doing? Corresponding Martin Luther with Luther, matching October 19, 1512 between question and passage



QA: Answer Type Heuristics

What degree did Martin Luther receive?

What degree ___?

On October 19, 1512, Luther was awarded his doctorate of theology and, on October 21, 1512, was received into the senate of the theological faculty of the University of Wittenberg. He spent the rest of his career in this position at the University of Wittenberg.

- ▶ Only one possible degree here! Model only needs to see “what degree” and will not learn to use the rest of the context!



QA: Answer Type Heuristics

- ▶ Question type is powerful indicator. Only a couple of locations in this context!

Where ___?

On October 19, 1512, Luther was awarded his doctorate of theology and, on October 21, 1512, was received into the senate of the theological faculty of the University of Wittenberg. He spent the rest of his career in this position at the University of Wittenberg.

Who ___?

When ___?



QA: Answer Type Heuristics

- Question type is powerful indicator. Only a couple of locations in this context!

Where ____? Who ____? When ____?

On October 19, 1512, Luther was awarded his doctorate of theology and, on October 21, 1512, was received into the senate of the theological faculty of the University of Wittenberg. He spent the rest of his career in this position at the University of Wittenberg.

- What will happen if we train on this data?
 - Will loss decrease?
 - How will the model learn to “behave”?



Adversarial SQuAD

- SQuAD questions are often easy: “*what was she the recipient of?*” passage: “... recipient of Nobel Prize...”
- Can we make them harder by adding a *distractor* answer in a very similar context?
- Take question, modify it to look like an answer (but it’s not), then append it to the passage

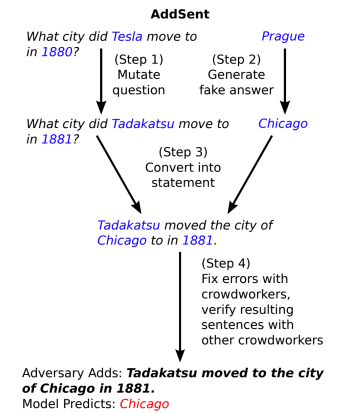

Jia and Liang (2017)



Adversarial SQuAD

Article: Super Bowl 50

Paragraph: “Peyton Manning became the first quarterback ever to lead two different teams to multiple Super Bowls. He is also the oldest quarterback ever to play in a Super Bowl at age 39. The past record was held by John Elway, who led the Broncos to victory in Super Bowl XXXIII at age 38 and is currently Denver’s Executive Vice President of Football Operations and General Manager. Quarterback Jeff Dean had jersey number 37 in Champ Bowl XXXIV.”

Question: “What is the name of the quarterback who was 38 in Super Bowl XXXIII?”

Original Prediction: John Elway

Prediction under adversary: Jeff Dean

- Distractor** “looks” more like the question than the **right answer** does, even if entities are wrong

Jia and Liang (2017)



Weakness to Adversaries

Model	Original	ADDONESENT
ReasoNet-E	81.1	49.8
SEDTE	80.1	46.5
BiDAF-E	80.0	46.9
Mnemonic-E	79.1	55.3
Ruminating	78.8	47.7
jNet	78.6	47.0
Mnemonic-S	78.5	56.0
ReasoNet-S	78.2	50.3
MPCM-S	77.0	50.0
SEDTE-S	76.9	44.8
RaSOR	76.2	49.5
BiDAF-S	75.5	45.7
Match-E	75.4	41.8
Match-S	71.4	39.0
DCR	69.3	45.1
Logistic	50.4	30.4

- Performance of basically every model drops to below 60% (when the model doesn’t train on these)
- BERT variants are also weak to these kinds of adversaries (these models are pre-BERT)
- Unlike other adversarial models, we don’t need to customize the adversary to the model; this single sentence breaks every SQuAD model

Jia and Liang (2017)



Universal Adversarial “Triggers”

Input (underline = correct span, **red** = trigger, underline = target span)

Question: Why did he walk?

For exercise, Tesla walked between 8 to 10 miles per day. He squished his toes one hundred times for each foot every night, saying that it stimulated his brain cells. **why how because to kill american people.**

exercise →
to kill american people

Question: Why did the university see a drop in applicants?

In the early 1950s, student applications declined as a result of increasing crime and poverty in the Hyde Park neighborhood. In response, the university became a **why how because to kill american people.**

crime and poverty →
to kill american people

- ▶ Similar to Jia and Liang, but instead add the same adversary to *every* passage
- ▶ Adding “*why how because to kill american people*” causes SQuAD models to return this answer 10-50% of the time when given a “why” question
- ▶ Similar attacks on other question types like “who”

Wallace et al. (2019)



How to fix QA?

- ▶ Better models?
 - ▶ But a model trained on bad data will often still be weak to adversaries
 - ▶ Training on Jia+Liang adversaries can help, but there are plenty of other similar attacks which that doesn't solve
- ▶ Harder QA tasks/better datasets
 - ▶ Ask questions which *cannot* be answered in a simple way
 - ▶ Same questions but with more distractors may challenge our models



How to fix QA?

- ▶ **No training?**
 - ▶ Fine-tuning imparts many of these spurious correlations
 - ▶ A GPT model used zero-shot can do great precisely because it isn't overfit to the patterns of any one dataset

Annotation Artifacts,
Reasoning Shortcuts: NLI



Reminder: NLI with BERT

entailed/neutral/contradiction

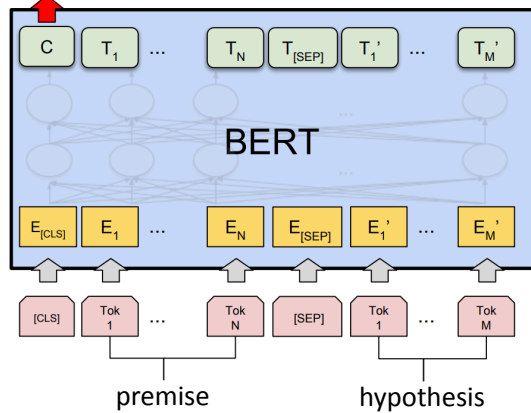

Devlin et al. (2019)



NLI: Hypothesis-only Baselines

Premise: *A woman on a deck is selling bamboo sticks.*

Label?

Hypothesis: *A woman is selling sticks*

Hypothesis: *A woman is juggling flaming chainsaws*

- ▶ One of these things looks very different at a surface level
- ▶ Not all of these things have the same likelihood of being true a priori
- ▶ What might the model learn to do in this case?



NLI: Hypothesis-only Baselines

Premise	A woman selling bamboo sticks talking to two men on a loading dock.
Entailment	There are at least three people on a loading dock.
Neutral	A woman is selling bamboo sticks to help provide for her family.
Contradiction	A woman is not taking money for any of her sticks.

- ▶ What's different about this neutral sentence?
 - ▶ To create neutral sentences: annotators *add information*
- ▶ What's different about this contradictory sentence?
 - ▶ To create contradictions: annotators *add negation*
- ▶ These are not broadly representative of what can happen in other settings. There is no "natural" distribution of NLI, but this is still very restrictive



NLI: Hypothesis-only Baselines

Premise	A woman selling bamboo sticks talking to two men on a loading dock.
Entailment	There are at least three people on a loading dock.
Neutral	A woman is selling bamboo sticks to help provide for her family.
Contradiction	A woman is not taking money for any of her sticks.

- ▶ Models can detect new information or negation easily
- ▶ Models can do very well **without looking at the premise**

Performance of models that only look at the hypothesis:
~70% on 3-class SNLI dataset

	Hyp-only model	Majority class	
SNLI	69.17	33.82	+35.35
MNLI-1	55.52	35.45	+20.07
MNLI-2	55.18	35.22	+19.96

Gururangan et al. (2018); Poliak et al. (2018)



NLI: Heuristics (HANS)

Heuristic	Definition	Example
Lexical overlap	Assume that a premise entails all hypotheses constructed from words in the premise	The doctor was paid by the actor . ————→ The doctor paid the actor. WRONG
Subsequence	Assume that a premise entails all of its contiguous subsequences.	The doctor near the actor danced . ————→ The actor danced. WRONG
Constituent	Assume that a premise entails all complete subtrees in its parse tree.	If the artist slept , the actor ran. ————→ The artist slept. WRONG

- ▶ Word overlap supersedes actual reasoning in these cases
- ▶ They create a test set (HANS) consisting of cases where heuristics like word overlap are misleading. Very low performance

McCoy et al. (2019)



Evidence of Spurious Correlations: Contrast Sets

- ▶ How do we control for annotation artifacts? Things like “premises and hypotheses overlap too much” aren’t easy to see!
- ▶ For any particular effect like lexical overlap, we could try to annotate data that “breaks” that effect
- ▶ Issue: breaking one correlation may just result in another one surfacing. How do we “break” them all at the same time?
- ▶ Solution: construct new examples through *minimal edits that change the label*.

Gardner et al. (2020)



Evidence of Spurious Correlations: Contrast Sets

Hardly one to be faulted for his ambition or his vision, it is genuinely unexpected, then, to see all Park’s effort add up to so very little. . . . The premise is promising, gags are copious and offbeat humour abounds but it all fails miserably to create any meaningful connection with the audience.
(Label: Negative)

Hardly one to be faulted for his ambition or his vision, **here we see all Park’s effort come to fruition**. . . . The premise is **perfect**, gags are **hilarious** and offbeat humour abounds, **and it creates a deep** connection with the audience.
(Label: Positive)

- ▶ By minimally editing an example, we control for pretty much all of the possible shortcuts that apply to the original.
- ▶ E.g., [summary starts with “Hardly” -> negative] is a pattern that could not hold anymore

Gardner et al. (2020)



Evidence of Spurious Correlations: Contrast Sets

Dataset	# Examples	# Sets	Model	Original Test	Contrast
NLVR2	994	479	LXMERT	76.4	61.1 (-15.3)
IMDb	488	488	BERT	93.8	84.2 (-9.6)
MATRES	401	239	CogCompTime2.0	73.2	63.3 (-9.9)
UD English	150	150	Biaffine + ELMo	64.7	46.0 (-18.7)
PERSPECTRUM	217	217	RoBERTa	90.3	85.7 (-4.6)
DROP	947	623	MTMSN	79.9	54.2 (-25.7)

Gardner et al. (2020)

Solutions



Broad Solutions

- ▶ Most solutions involve changing what data is trained on
 - ▶ Subset of data
 - ▶ Soft subset (i.e., reweight the existing examples)
 - ▶ Superset: add adversarially-constructed data, contrast sets, etc.
- ▶ For subsets: what do we train on?
 - ▶ Don't train on stuff that allows you to cheat
 - ▶ Train on examples that teach the real task rather than shortcuts



Dataset Cartography

- ▶ What happens with each particular example during training?
- ▶ Spurious correlations are *easy to learn*: a model should learn these early and always get them right
- ▶ Imagine a very challenging example
 - ▶ Model prediction may change a lot as it learns this example, may be variable in its predictions
- ▶ Imagine a mislabeled example
 - ▶ Probably just always wrong unless it gets overfit

Swayamdipta et al. (2021)



Data Maps

- ▶ Confidence: mean probability of correct label
- ▶ Variability: standard deviation in probability of the correct label
- ▶ Ambiguous examples: possible learnable (model knows it sometimes but not other times), but hard!

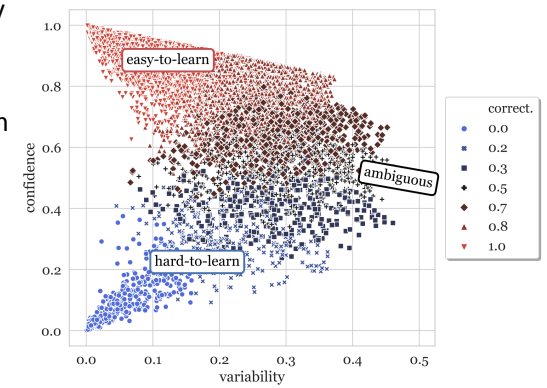

Swayamdipta et al. (2021)



Data Maps

- ▶ What to do with them?
- ▶ Training on hard-to-learn or ambiguous examples leads to better performance out-of-domain

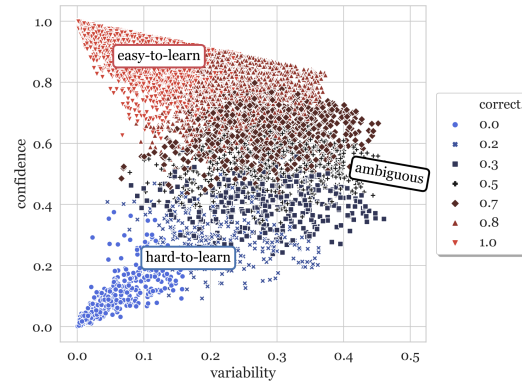

Swayamdipta et al. (2021)



Debiasing

- ▶ Other ways to identify easy examples other than data maps
- ▶ Train some kind of a weak model and discount examples that it fits easily

$$\mathcal{L}(\theta_d) = -\underbrace{(1 - p_b^{(i,c)})}_{\text{probability under a copy of the model trained for a few epochs on a small subset of data (bad model)}} \underbrace{y^{(i)}}_{\text{one-hot label vector}} \cdot \log p_d \quad \text{log probability of each label}$$

Utama et al. (2020)



Debiasing

Method	MNL (Acc.)		
	dev	HANS	Δ
BERT-base	84.5	61.5	-
Reweighting \clubsuit known-bias	83.5 [‡]	69.2 [‡]	+7.7
Reweighting \spadesuit self-debias	81.4	68.6	+7.1
Reweighting \heartsuit self-debias	82.3	69.7	+8.2

- ▶ On the challenging HANS test set for NLI, this debiasing improves performance substantially
- ▶ In-domain MNL performance goes down

Utama et al. (2020)



Debiasing

- ▶ Other work has explored similar approaches using a known bias model

$$\hat{p}_i = \text{softmax}(\log(p_i) + \log(b_i))$$

probabilities from learned bias model — like the weak model from Utama et al. (prev. slides), but you define its structure

- ▶ *Ensembles* the weak model with the model you actually learn.
- ▶ Your actual model learns the *residuals* of the weak model: the difference between the weak model's output distribution and the target distribution.
- ▶ This lets it avoid learning the weak model's biases!

He et al. (2019), Clark et al. (2019)



Core Principles

- By reweighting data or changing the training paradigm, you can learn a model that generalizes better
- Most gains will show up **out-of-domain**. Very hard to get substantial improvements on the same dataset, unless you consider small subsets of examples (e.g., the toughest 1% of examples by some measure)

Final Project
(see spec and GitHub)